

Specifications

Output Power HP (kW)	7.5 (5.5)
Phase	3 Phase
Pole	6 Pole
Frame Number	132M

Degrees of Protection	IP 55
Enclosure Construction	Totally-enclosed Fan-cooled
Thermal Class	Class F (155 °C)

Alignment	Horizontal
Frame Material	Steel plate

Power Transmission	Direct-couple or Belt Driven
Direction of Rotation	Counterclockwise (CCW) viewed from shaft-end side

Connection Type	Terminal Block (6 Leads)
Coating Colour	Munsell N5.5 (Gray)
Conformed Standard	IEC 60034-1 & JEC-2137-2000

Voltage & Frequency	LT Type	
	220/380~415V	50Hz
	220/440V	60Hz

* The perpendicular variation of tolerance for the shaft center is ± 0.5

Dimensions (mm)

Motor														
A	B	C*	D	E	F	G	H	I	J	K	L	M	ML	N
230.5	174	132	266	108	89	6.5	265	288	40	45	488.5	256	268	218

Motor			Terminal Box				Shaft End						
X	XB	Z	KA	KG	KD	KL	Q	QK	R	S	T	U	W
4	89	12	94	96	PF 1	210	80	63	258	38 k6	8	5	10

Bearing No.		Approximated Weight (kg)	Approximated Packing Dimensions (LxWxH)	Gross Weight (kg)
Drive End	Opposite			
6308ZZ	6207ZZ	61	579 x 435 x 347	69

Connection & Connection Diagram

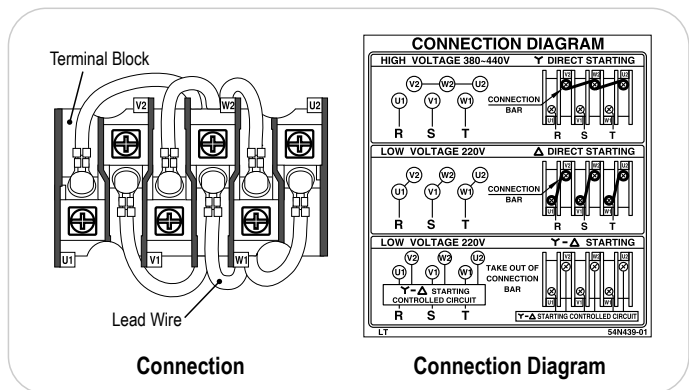

Circumstance Conditions

Ambient Temperature	-20 ~ +40°C
Ambient Humidity	95% RH or less
Operating Altitude	Less than 1,000m above sea level
Environment	No bursting / erosive gas or vapor

Motor Characteristics

Type	Hz	V	50% Load			75% Load			100% Load				Torque(%)		Is (A)	Inertia GD ² (kg-m ²)	
			(A)	Eff(%)	PF(%)	(A)	Eff(%)	PF(%)	(A)	Eff(%)	PF(%)	Speed (r/min)	Torque (kg-m)	Ts			Tm
LT	50	220	14.1	0.85	0.60	17.3	0.87	0.72	21.3	0.87	0.78	950	5.64	246	234	135	0.181
		380	8.14	0.86	0.60	10.0	0.87	0.72	12.3	0.87	0.78	950	5.64	246	234	77.8	
		415	9.12	0.82	0.51	10.6	0.85	0.63	12.5	0.86	0.71	960	5.58	293	279	85.0	
	60	220	11.8	0.87	0.70	15.4	0.89	0.79	19.7	0.89	0.82	1140	4.70	195	204	111	
		440	7.26	0.85	0.59	8.7	0.89	0.70	10.5	0.89	0.77	1150	4.66	266	273	74.2	